

Paradiso 1 FS1030

Mobile TV multistandard baseband IC for T-DMB and DVB-H

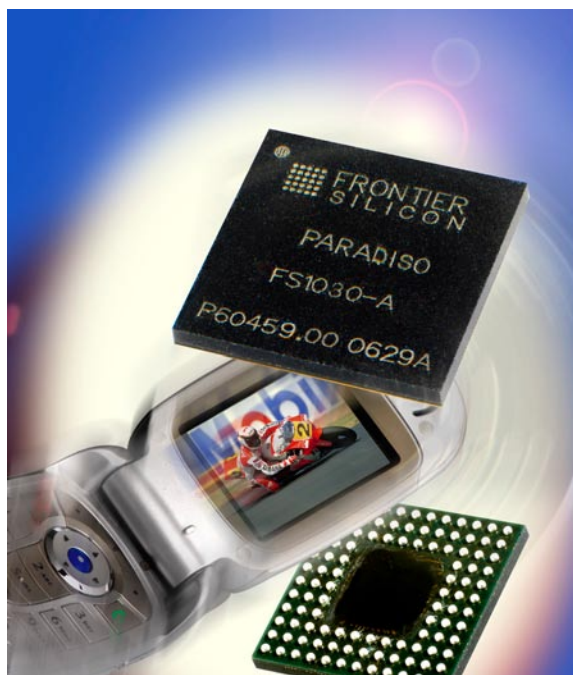

Compact footprint - 8.0 x 8.0 x 1.0 mm

APPLICATIONS

- Mobile phone with TV
- Personal media player
- Automotive infotainment system
- Mobile/portable TV terminal
- Portable DVD player
- Mobile TV dongle
- Mobile TV enabled laptop/PC

OVERVIEW

Paradiso 1 is an advanced multistandard baseband receiver, enabling mobile TV, audio and data services on handheld devices for worldwide markets, with industry-leading performance, size and cost.

Supporting all DVB-H, DVB-T, DAB, T-DMB and DAB-IP modes, including Chinese, European and Korean, Paradiso 1 is designed to be used with a host media processor and an RF front-end such as the Frontier Silicon *Apollo*.

Paradiso 1 offers **unmatched flexibility**, with features such as advanced Doppler and multipath channel performance, integrated RAM, variable IP stream rates, support for conditional access, and a comprehensive set of peripheral interfaces, simplifying system integration.

Host processor interfaces include SPI, SDIO and USB 2.0. The software data plane supports streaming outputs for TS, FIC, MSC, PSI/SI and IP data payloads. The software control plane supports remote boot and optimized baseband control. All interfaces are flexible to facilitate custom host communication protocols. Paradiso 1 can boot, stream data and be controlled through any of the above host processor interfaces, simplifying design and deployment; additional boot and control options are available through UART and SCP.

Paradiso 1 uses a 1.2 V core **power supply**, and 1.8 - 3.3 V for I/O. This can be implemented using a single 1.8 - 3.3 V input with the integrated SMPS controller, simplifying design of non-cellular products.

KEY FEATURES

- Advanced IC for all DVB-H, T-DMB, DAB, DVB-T and DAB-IP applications
- 8 x 8 x 1 mm ultraslim 132-pin VFBGA package for slim-phones and low-profile devices
- Low power operation with advanced power management
- Supports numerous DMB variants including T-DMB, DxB, DAB-IP and BT Movio
- Enhanced packet and enhanced data group modes
- PID filtering with additional IP filtering
- Dual ADC with analog input mux supports ZIF/LIF interfaces to both single- and multi-standard tuners
- Flexible hardware-assisted DSP architecture
- Decodes multiple video, audio and data services up to maximum 1.8 Mbps (T-DMB) or 33 Mbps (DVB-H)
- Programmable communication processor has capacity for the most demanding digital receiver standards
- Flexible transport interface for data transfer to multiple video decoders
- On-chip MPE-FEC and Reed-Solomon decoder for best mobile channel performance
- Data service support to the host processor
- Supplied complete with *DeNiro* host drivers and embedded firmware
- Full evaluation system available, with flexible modular design to accept a choice of T-DMB, DVB-H and multistandard tuner ICs
- Integrated SMPS for single 1.8 - 3.6 V supply
- Wide temperature range:
 - Operation -40 to +85 °C;
 - Storage -60 to +125 °C
- Full RoHS compliance

WWW.FRONTIER-SILICON.COM



**FRONTIER
SILICON**

Paradiso 1 FS1030

Mobile TV multistandard baseband IC for T-DMB and DVB-H



INTEGRATED CHIPSET SOLUTION

Paradiso 1 has been designed as part of a complete mobile TV chipset, along with Frontier Silicon's T-DMB multiband RF tuner *Apollo FS1110*. The combined chipset provides the best-performing solution for T-DMB, with industry-leading sensitivity, power consumption, footprint and cost. Alternative tuner ICs for DVB-H are designed in as part of the Paraglide evaluation system.

SUPPORTED STANDARDS

Paradiso is compliant with the following mobile TV/radio standards and guidelines:

- ETSI EN 302 304 (DVB-H)
- ETSI EN 300 744 (DVB-T)
- ETSI EN 300 401 (Eureka-147 DAB)
- ETSI TS 102 427 (T-DMB)
- ETSI EN 301 192 (DVB-DATA)
- ETSI ES 201 735 (DAB IP)
- ETSI TR 101 202 (DVB Implementation Guidelines)
- ETSI TR 101 211 (DVB Implementation Guidelines for Service Information)
- MBRAI v1.0 (Mobile and Portable DVB-T/H Radio Access Interface)

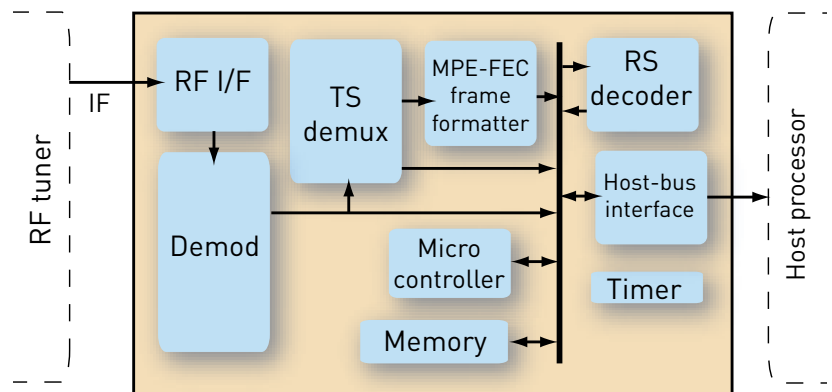

Paradiso 1 block diagram

DATA INTERFACES

Host processor interfaces include SPI, SDIO and USB for both control plane and bulk data plane. Bulk data output supports FIC, MSC, TS, PSI/SI information and IP datagrams.

- SDIO: Secure digital I/O interface to media processor, at up to 100 Mbps. Supports all SPI, 1-bit and 4-bit device modes
- SSI: Dual high-speed synchronous serial channels to media processor, each up to 24 Mbps transfer rate, with master/slave capability
- USB: Full-speed device or host controller, up to 12 Mbps. with embedded buffer and ancillary functions

CONTROL INTERFACES

- SCP: Dual serial interfaces to control RF tuner and interface to media processor
 - UART: Standard 16550-compatible interface up to 1.5 Mbaud
 - GPIO: General purpose I/O multiplexed with other non-functional pins to reduce pinout
 - EMI: Optional interface to 8 Mb of off-chip cellular RAM to support contiguous bursts
 - PDM: Optional PDM DAC interfaces for control of external tuner wide and narrowband AGC loops
- Paradiso 1 can boot, stream data, and be controlled through any of SPI, SDIO and USB - simplifying design and deployment. Additional boot and control options are available through the UART and SCP interfaces.

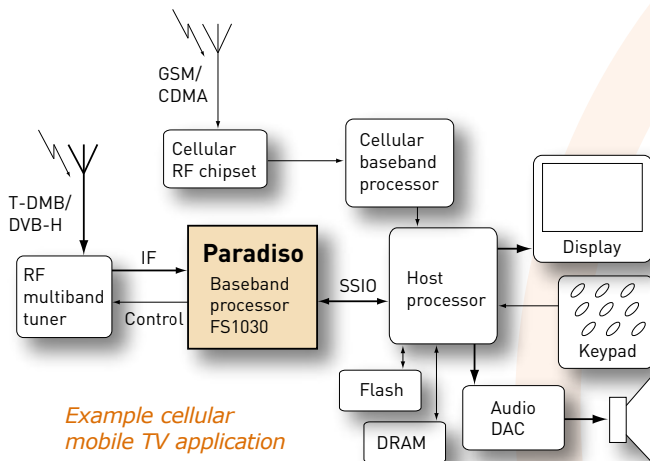

Example cellular mobile TV application

Actual size

132 VFBGA, 0.5 mm pitch



WWW.FRONTIER-SILICON.COM